



**The Sea Cadet Corps – Marine Cadet Section
Company Commanders & Company Sergeant Major’s Conference**



**M I N U T E S
9th May 2009 – Naval Regional Headquarters Merseyside**

Agenda Item No	SATURDAY	Action(s)/ Appendices
1	<p>Present:</p> <p>CSgt M Allen RM (SRMO) Major (SCC) I Machin RMR (X-Ray Coy Cdr) Lt (SCC) I Malloch RMR (Yankee Coy Rep) Major (SCC) G Guppy RMR (Zulu Coy Cdr) Major (SCC) I Devenish RMR (Alpha Coy Cdr) Major (SCC) P Carroll RMR (Lima Coy Cdr) Capt (SCC) S Scholes RMR (Bravo Coy Rep) Lt (SCC) G Johnstone RMR (HQSO WT) WO1 (SCC) G D Robinson RMR (RSM) WO2 (SCC) A Kelly RMR (Zulu CSM) WO2 (SCC) P Wagstaff RMR (Alpha CSM) CSgt (SCC) I Anderson (X-Ray CSM)</p> <p>In attendance: Lt (SCC) F Taylor RNR (HQ Coy Clerk)</p>	
2	<p>Apologies/Thanks:</p> <p>Apologies: Major (SCC) D Poke RMR (HQSO AT) Thanks: Patricia Humphreys for providing the buffet and refreshments</p>	
3	<p>Absentees:</p> <p>None</p>	
4	<p>Introduction from AO(NW) – Lt Col John DAVIES RM:</p> <p>Lt Col Davies welcomed the delegates to RNHQ Merseyside, and stated that he would hope that the venue be utilised again in the future. He went on to introduce himself to the group, stating that he was settling into the role of AO. The AO impressed on the group that the emphasis around Cadet training should be safety, fun and management. He summarised by assuring SRMO/RSM that he would welcome the opportunity to provide advice and support with any matters required.</p>	
5	<p>SRMO’s Opening Remarks:</p> <p>SRMO gave an introductory brief on his first four months in post. He went on to congratulate Major and Mrs Devenish on the birth of their first child, Alexander.</p>	
6	<p>Minutes of the Last Meeting:</p> <p>The following minute points were highlighted by SRMO:</p>	

Agenda Item 7: Potential Detachment Update:

Company	Current State	Embryo Dets	Pipeline Applications
Alpha	18	0	2
Bravo	34	2	3
Lima	11	0	1
X-Ray	16	1 Closure	
Yankee	10	0	1
Zulu	20	0	1

Agenda Item 11: Field Assessment Dates 2010 – Alpha and X-Ray have responded so far. For further information, please see the document at [Annex A](#) to these Minutes. Forward dates to the RSM ASAP

Agenda Item 16: Warrant Officer Selection Board – Unfortunately, the Board due to convene in February 2009 was cancelled due to bad weather. This has been re-scheduled for June 2009, the details of which are available on Westminster.

Discussion with CSC during last Conference (not a numbered agenda item):

The issue of Tp Cmdrs not being invited as delegates to DO's Conference –

CSC has stated that Marine Cadet personnel will receive an invitation to Conference if there are specific Marine Cadet Section issues on the agenda. It was generally agreed that Tp Cmdrs should have a permanent invitation to Conference, if the stated intention of full integration as a Corps were to come to fruition. It was noted that the majority of DO's asked at Conference whether they would support the invitation of Tp Cmdrs, stated that they would welcome the input of their Marine Cadet colleagues.

Radios and Comms Systems –

CSC has investigated the possibility of the Marine Cadet Section moving onto the Bowman Digital Communication System, as a replacement for the Clansman. It was stated that, due to financial constraints, the introduction of the Bowman DCS will suffer a short delay. SRMO went on to say that the current Clansman system is aging and requires almost constant maintenance and repair. It was agreed to find a source for replacement batteries and peripherals.

ACTION COY CDR'S

*** PMN – RMR Mersey have a selection of Clansman spares which they will provide for us.**

Marine Cadet Section Rebrand to 'Royal Marine Cadets' –

Col Cautley has spoken to CSC with regard to the proposed rebrand, with particular reference to the provision of new shoulder titles (Cadets only). CGRM is in agreement, but Col Cautley awaits the agreement and support of 2SL. Overall, it was reported that very positive feedback had been received with regard to the rebrand, although it was thought that the issue of liability for the DRFC had prohibited the project in the past.

2009 Trafalgar Celebrations –

For this year, it was reported that the MC commitment would be provided by X-Ray and Zulu Coys, who will be required to provide: 1 Officer, 1 Senior and 30 Cadets per Company.

Agenda Item 27: Webbing, Bergens and Uniform for new Dets – SRMO stated that there had been very little movement on this issue, in that the Corps was still only being scaled for 90 Patt. A contact is being sought from within the Bicester infrastructure to check whether this can be re-scaled. At present, unserviceable kit cannot be recycled iaw current MOD policy due to the UIN difference. It was felt by all that the issue of webbing and ancillaries should be an SCC Stores concern. The previous SRMO contacted FOSNNI with regard to this issue, but received no reply. It was also discussed that the original Scale of Issue Project was generated and circulated from this forum.

Agenda Item 29: Detachment Numbers – SRMO reiterated that SCR doe NOT state that there is a cap on the number of Marine Cadets which can be recruited (dependent on the compliment of the Bluejacket Ship's Company). It was felt that some COs still regarded the number capping regulations as extant, and that the abolition of this regulation should be more widely advertised. It was also felt that an HQTM should be published in order that this issue be resolved. RSM went on to state that, from the end of May 2009, the paper-based publication and distribution of HQTMs would cease, as a cost-saving exercise. All future HQTM-type notices and publications would be featured on the MSSCHQ Training and Administration web site: www.sccheadquarters.com

Agenda Item 32: Clay Pigeon Shooting – HQSO(WT) reiterated to all that Clays is a legitimate SCC activity and should be more widely advertised. He did, however, ad the caveat that all personnel invited to conduct Clays training should be appropriately qualified and provide RASP/EASP documentation for each

* ACTION SRMO – AO (NW) to be approached to provide some assistance with this contact and to move the issue forward.

* ACTION SRMO – An e-HQTM is to be drafted to reiterate this to all.

* ACTION SRMO/RSM – To discuss with Cadet activity planners at HQ Land Forces Wilton

	<p>activity.</p> <p><i>Obstacle Course Supervisor Course</i> – It was reported that a member of staff from Alpha had attempted to apply for this course, which was to be conducted by the ACF. He was told that he was not eligible to apply due to the course not being open to the SCC. It was generally felt that Westminster now provides the visibility and opportunity for cross-training, which had previously, been difficult to obtain and that a greater number of course could be adapted for cross-training, in addition to CLC courses and KGV1.</p> <p>The minutes of the last meeting (Nov 2008) were agreed as a true record by Maj Carroll and seconded by WO2 Wagstaff.</p> <p>It was also requested that the draft Minutes should be distributed to conference delegates for their comments prior to full distribution. This will be done.</p>	
7	<p>Coy Cdr and CSM Terms of Reference (TORs):</p> <p>Alpha Coy Cdr reported that at least two years worth of work had been carried out on this project. SRMO reported that CSC is yet to agree to content of the TORs. Some discussion ensued as to whether MC training will fall within the ATO's remit, and that this should be reflected in the TORs. A discussion between CSC/SRMO has resulted in CSC agreeing to sign off the TORs for CSM. CSC will go on to staff TORs as a collective workstrand. This work is due to be completed by year-end. Following this, Coy Cdr's TORs will be released as a complete pack along with the Bluejacket posts. Annex B to these Minutes was distributed and discussed.</p> <p>The message from CSC is integration and standardisation across the Corps is key to its future success. This statement resulted in further discussion around the fact that Marine Cadet personnel should be represented at ALL levels of discussion. It was felt that, only when MC matters were represented in every forum, could true Corps integration take place. To that end, the following statements were considered to be vital in aiding this integration: SRMO should be (and used to be) invited to attend AO's Meetings; an MC rep should be invited to attend SSO's Conferences; Coy Cdr should be invited to attend SMT/Exec Meetings at Area level. It was also felt that communications between Bluejacket and Marine Cadet staff need to improve at all levels in order to take the integration initiative forward.</p>	<p>* ACTION SRMO – discuss with CSC and provide guidance to all personnel convening meetings and conferences</p>

8	<p>Coy Cdr/CSM Conference:</p> <p>It was reported that this conference would now only convene once per year, due to budgetary constraints. However, it was felt that this would be helped by the fact that the National Marine Cadet Summer Camp would also provide an excellent opportunity to convene an additional meeting. It was also felt that the possibility of convening the SSO Conference on the same weekend would be beneficial to the points raised in Agenda Item 7, in that the Coy Cdr/CSM and SSO meetings could be conducted separately on the Saturday, with a joint meeting on the Sunday.</p>	<p>* ACTION SRMO – combine the discussion around a joint meeting with the action from Item 7</p>
9	<p>Coy Training Officers attendance at Coy Cdr/CSM Conference:</p> <p>A discussion ensued as to the validity of inviting CTOs to this forum. It was felt that CTOs would benefit more if invited to the National ATO Conference.</p>	<p>* ACTION SRMO – Raise with CSC</p>
10	<p>Area ORBAT Update:</p> <p>Alpha Coy Cdr stated that the ORBAT already provided was in a period of re-negotiation.</p>	
11	<p>Gibraltar Cup 2008:</p> <p>Congratulations to Zulu Coy (Jersey Det) - 2008 Winners. SRMO stated that, sadly, Major Poke was unavailable to report on the competition due to ill-health. X-Ray Coy Cdr reported that the marks awarded and reported as a result of the bottom field activities appeared contentious. SRMO stated that he would ensure fairness at the next competition by discussing the scores with Coy Cdrs prior to the presentations, to ensure that all were in agreement. Also, he maintained that he would provide a comprehensive briefing to CTCRM Staff prior to the competition. CSM Lima asked whether Ranks could be capped to maybe one Sgt and one Cpl per team? It was generally agreed that capping would not work, in that the team nominated at the selection time would not necessarily have those Ranks by the time of the competition due to leavers and promotions. It was agreed that no capping would take place.</p>	<p>Motion: No capping of Ranks within a team agreed</p>
12	<p>Attendance at DO's Conference:</p> <p>Already covered in Item 6.</p>	
13	<p>Confirm Field Assessment Dates for 2009 and 2010:</p> <p>The FA dates are published at Annex C to these minutes. It was also stated that any Detachments which do not attend their Field Assessment must submit their reasons in writing to SRMO as soon as possible.</p>	

14	<p>National Drill Competition:</p> <p>RSM congratulated the Companies that attended, in particular Alpha Company – the winners. He went on to state that the standard of drill had improved since the last competition, which was encouraging. On a slightly negative note, Bravo Coy pulled out at the last minute, and Lima Coy did not provide an entry either. RSM requested that reasons for non-attendance be submitted in writing as soon as possible. It was mentioned that the Colour Party competition should be restricted to Bluejacket teams only, as the confusion as to the differences in MC drill are noticeable and are not always accurate.</p>	<p>* ACTION RSM – investigate the possibility of restricted entry to the Colour Party Competition with HQSO P&C</p>
15	<p>Marine Cadet Arduous Course at CTCRM:</p> <p>It was noted that this course has been extended to enable applications from 40 Cadets, with the next available course scheduled for 20-25 September 2009. Entries via Westminster please.</p>	<p>* ACTION Coy Cdrs – ensure that these courses are widely publicised</p>
16	<p>Marine Cadet Basic and Intermediate Courses:</p> <p>The next scheduled Basic Course will run from 12-17 July 2009, with the Intermediate Course running from 19-24 July.</p>	
17	<p>Drill Leader Qualifying Course:</p> <p>It was reported that next course, due to run from 14-19 June 2009, currently had one applicant. The course has been re-opened on Westminster. It was also noted that Yankee Coy require qualified DLs, so should be encouraged to apply.</p>	<p>* ACTION ALL</p>
18	<p>Exercise Bavarian Surprise:</p> <p>SRMO reported that the ten Cadets who attended the last exercise had a fantastic time, and conducted themselves very well indeed. Due to the weather conditions, the Cadets gained mainly ski qualifications. The next course will run from 23-31 August 2009, and there are six applicants already. It was stated that Cadets who failed to attend the course without a valid reason given in advance, would be charged £300 to cover costs.</p>	
19	<p>KGVI Course at CTC Frimley Park:</p> <p>The course is going well, but has changed slightly in that all candidates are required to follow the same course syllabus, regardless of cap badge. It was reiterated that NO direct applications are to be made to Frimley Park. There are two places available on each course. If applicants' Line Managers need to provide justification as to the selection of a particular applicant on a particular course, they may use the Notes field provided during the Westminster course application wizard.</p>	

20	<p>Activity First Aid:</p> <p>It was reported that there had been some changes within the syllabus, with the introduction of the St John Ambulance system. It was also stated that JSP 535 is to be revised to encompass all First Aid qualifications, for clarity. As previously discussed the 'Combat Medic' course, piloted by the NW Area, is to be discontinued forthwith.</p>	
21	<p>Weapons Qualifications:</p> <p>HQSO (WT) reiterated the fact that instruction in ALL current weapons systems would be delivered during the Weapons Handling Instructor course. Questions were asked as to why WHI courses were not weapon-specific. HQSO replied by stating that WHIs should have the ability to teach all types of weapon, in addition to the current main weapons system at the time of qualification. The main point is that WHIs should be qualified, competent and current. HQSO went on to state that the Weapons Instructor course had been re-written, and will be delivered shortly. The discussion then moved on to the Ammunition Storeman's Course, which instructs students in the handling of full-bore ammunition at Establishments. Alpha Coy Cdr asked whether the ACF had been asked to attend an additional course which delivers training in weapons movements – SRMO to investigate.</p>	<p>* ACTION SRMO – investigate the validity of the additional ACF course with HQ Land Forces</p>
22	<p>Weapons Fielding Update:</p> <p>RSM began by stating that the fielding plan covers the three weapon variants: General Purpose (GP), Drill Purpose (DP) and Parade Purpose (PP).</p> <p>Allocation - The Corps allocation is reported as: 333 x GP Weapons; 270 DP Weapons and 3,564 PP Weapons. GP weapons will be issued with blank firing systems. ALOs will shortly publish the fielding plans and allocation numbers to their respective Areas. DPs will only be issued to Units with Marine Cadet Detachments. ALOs have already planned the delivery of crates to recover the existing weapons systems.</p> <p>Delivery - Dates are subject to delay due to a combination of Operational commitments and also issues around bayonet fixings. The ACF will hold a pool of ancillaries to account for breakages and in-service defects. When tasked to conduct tri-Service London Ceremonial (such as Cadet 150), the PP weapons will be drawn from London Area's additional allocation.</p> <p>Pam 5 does not currently include a WHT – this is being revised.</p>	<p>* ACTION MCDO – investigate with Adult Steering Group</p>

	<p>Sights – The sights from the current weapons system are to be retained for the new system.</p> <p>It was stated that Fleet Security will now conduct 10% of all SCC armouries.</p> <p>Alpha Coy Cdr asked when the new weapons system would be fielded at the National Drill competition. RSM stated that the 2010 Competition will see the introduction of the new weapons, but will have a permitted mix of weapons systems – if the new system remains unavailable to all Areas.</p>	
23	<p>A2 Conversion Courses:</p> <p>It was stated that an agreement had been made whereby the ATC/ACF will offer the initial conversion course to key SCC personnel, who will then roll out the training to other personnel. The conversion course will require between one and one and a half day's training. It was also stated that those personnel in date for WHT on the existing system will NOT carry their qualification over, and the new system will require a new WHT. See Annex Di and Dii to these minutes for information regarding conversion.</p>	
24	<p>Unit Ammunition Management System (UAMS):</p> <p>From 1st April, materiel management guidelines and rules will change to the DII system. To that end, UAMS will only be used when ALL Area Offices have access to DII. Further information regarding UAMS can be gained by reading the document embedded opposite. The ammunition requirements have already been ordered for 2009. SRMO went on to suggest that SCC Stores should have a DII account for munitions materiel management.</p>	 JSP886 v1.4.pdf
25	<p>Norway 2010:</p> <p>Unfortunately, due to instructor injury, the 2009 course was cancelled. SRMO stated that Major Paul Matting would undertake the 2010 course. Awaiting dates and costings.</p>	<p>* ACTION SRMO – add to Westminster when dates and costs available</p>
26	<p>Trafalgar Celebrations 2010-2011:</p> <p>The MC commitment for the above ceremonial is as follows:</p> <p>2010 - Bravo and Lima Companies – 2 Platoons 2011 – 48 Guardsmen from Alpha and Zulu Coys</p> <p>There will be no drill display for 2009, it is increasingly difficult to assemble team for training and is time-consuming. There will, however, be a MC Guard every 4th year, on a rotational basis.</p>	

<p>27</p>	<p>Budget for Company Courses:</p> <p>Alpha Coy Cdr requested that Coy budgets be addressed/revisted in light of the requirement to deliver the new Core Skills courses at Coy level? Also, he reported that the Alpha Coy budget has been cut to the point whereby some mandatory courses will need to be reduced.</p> <p>Answer: There continues to be a considerable strain on all budgets for this training year. There was general agreement that financial constraints were having a significant impact on training across the board. It is envisaged that budgets will be reduced by 6-10% due to the current financial climate.</p>	<p>* ACTION SRMO – appraise CSC of the budgetary pressure of devolving mandatory Core Skills training to Areas/Coys</p>
<p>28</p>	<p>Publication of Coy Grades:</p> <p>Alpha Coy Cdr opened by stating that, historically, Detachment Gradings were published via the Burgee/Pennant HQTM in January each year. This has discontinued now that the rolling system of efficiency awards has been introduced. However, Det Gradings were not conducted using the rolling system, and should still be published.</p> <p>A discussion ensued around this topic and the wider picture of gradings captured at FAs. There was some confusion as to the nomenclature of marks and grades, in that some were numerical, and some were worded, such as ‘Very Good Superior’ etc.</p> <p>SRMO agreed that final gradings for Dets should be decided and published by him.</p>	<p>* ACTION SRMO – Check SCR for MC grading rules and regulations. Also – look to standardise the nomenclature of marking systems to ensure clarity</p>
<p>29</p>	<p>Tactical Recognition Flash (TRF) Badges:</p> <p>The delegates were shown some images for suggested TRF for wear with CS95 – Annex E to these minutes. The group decided as a whole that they would present a costly and unnecessary addition to the badge catalogue.</p> <p>Decision - no TRFs to be introduced in the Corps.</p> <p>Some discussion ensued regarding the issue of DPM vs Black on Green rank slides. It was decided that either format was acceptable.</p>	
<p>30</p>	<p>Current Company Training Courses:</p> <p>RSM stated that a Training Strategy Group had been established in order that all courses delivered by the SCC have an agreed format and content. All courses should be staffed by the Group prior to them being approved and added to the course catalogue.</p>	<p>* ACTION ALL – Coy Cdrs to submit details of courses currently being delivered</p> <p>* ACTION RSM – send Training Proposal Form to Coy Cdrs</p>

<p>31</p>	<p>National Marine Cadet Summer Camp:</p> <p>Camp 2009 will run from 25th July to 1st August at Okehampton ATE. There will be a recce for Coy Cdrs on Saturday 27th June, details of which have already been sent to the invitees.</p> <p>Zulu Coy Cdr stressed the importance of ensuring adult training does not supersede Cadet supervision, which remains paramount.</p> <p>Cadets will remain within existing Coy structures, although staff may be re-deployed to avoid gaps in smaller Coys.</p>	<p>* ACTION ALL – Coy Cdrs to check application levels on Westminster in the weeks before Camp</p>
<p>32</p>	<p>Any Other Business:</p> <p>Yankee Coy Rep: Reported that Capt Storey is to return as stand-in Coy Cdr.</p> <p>HQSO (WT): Reminded all of the availability of BFSS training. Please advise him if you require a course to be run in your Area, providing a suitable venue and applicants are established. Also, new BFSS(T) system has been published and is available.</p> <p>Bravo Coy Rep: Stated that the next Cadet Sgt Board has been cancelled due to lack of applicants. The next Board will run soon.</p>	
<p>33</p>	<p>Date and Location of Next Conference:</p> <p>Next Conference to be held 19/20 June 2010 – Venue TBC.</p>	

THE SEA CADET CORPS – MARINE CADET SECTION
2009 & 2010 FIELD ASSESSMENT DATES

2009

<u>COMPANY</u>	<u>DATE</u>	<u>TRAINING AREA</u>	<u>REMARKS</u>
Bravo	2 nd May 2009	Nesscliff	Completed
Bravo	16 th May 2009	Nesscliff	
Zulu	4 th July 2009		Jersey Field Assessment?
Zulu	5 th July 2009?		Jersey Field Assessment?
Lima	5 th Sept 2009		
Alpha	12 th Sept 2009	Swynnerton	
Zulu	19 th Sept 2009		Guernsey Field Assessment?
Zulu	26 th Sept 2009		Guernsey Field Assessment?
X-Ray	3 rd Oct 2009		Including Malta (TBC)
Alpha	17 th Oct 2009	Caerwent	
X-Ray	24/25 th Oct 2009		Malta Field Assessment (TBC)
Yankee	31 st October 2009	Garelochhead Camp	

2010

<u>COMPANY</u>	<u>DATE</u>	<u>TRAINING AREA</u>	<u>REMARKS</u>
Alpha	11 th Sept 2010	Swynnerton	
X-Ray	2 nd Oct 2010		
Alpha	9 th Oct 2010	Caerwent	
X-Ray	16/17 Oct 2010	Malta	Malta Field Assessment
Bravo			
Bravo			
Bravo			
Lima			
Yankee			
Zulu			
Zulu			

SCC OPERATIONAL MANAGEMENT OF UNIFORMED ACTIVITIES

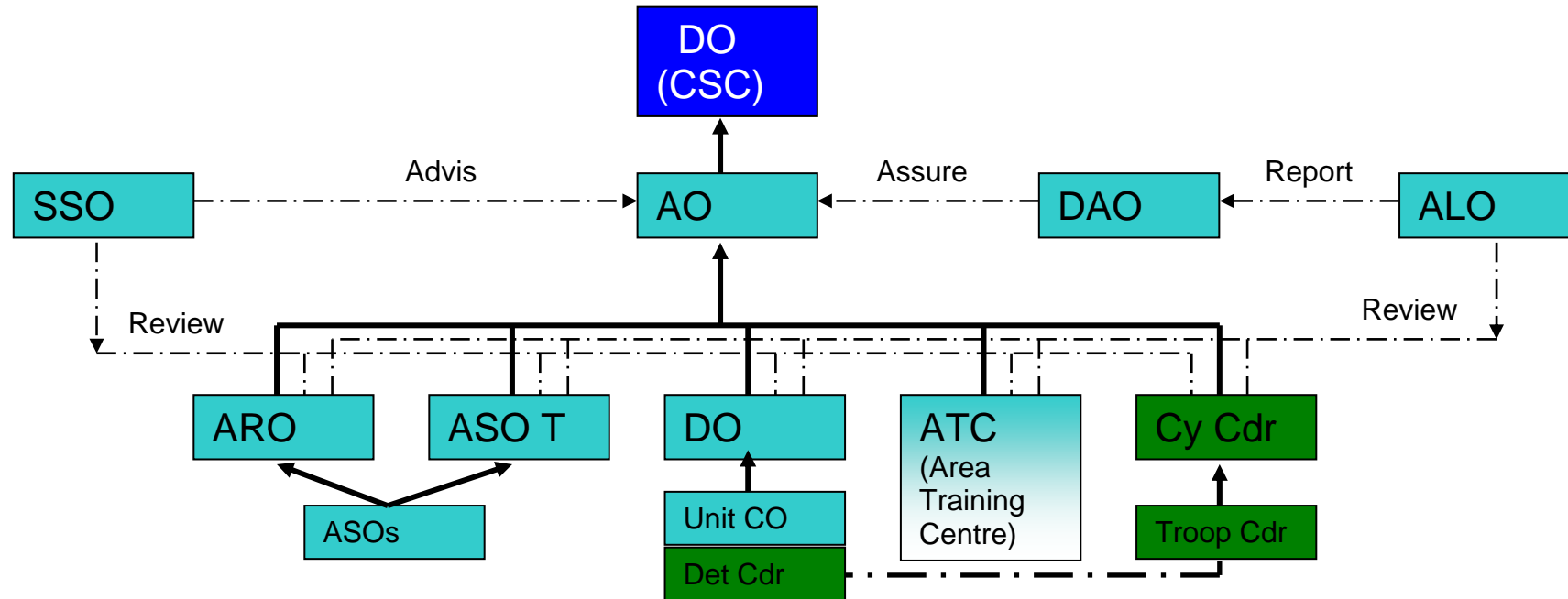

Responsibility

Y

Planning
Management
Safe Delivery
Welfare
Financial

Scope

Area
Competitions
Area Events
Area Camps

Responsibility

Y

Planning
Management
Safe Delivery
Welfare
Financial

Scope

Area Training
Area Camps

Responsibility

Y

Planning
Management
Safe Delivery
Welfare
Financial
Inspection

Scope (District)

Training
Competitions
Events
Camps

Responsibility

Planning
Management
Safe Delivery
Welfare
Financial

Scope

Full range of activities authorised for the Training Centre

Responsibility

Planning
Management
Safe Delivery
Welfare
Financial
Inspection

Scope

(Company)
Training
Competitions
Events
Camps

OPERATIONAL RESPONSIBILITY OF ASO

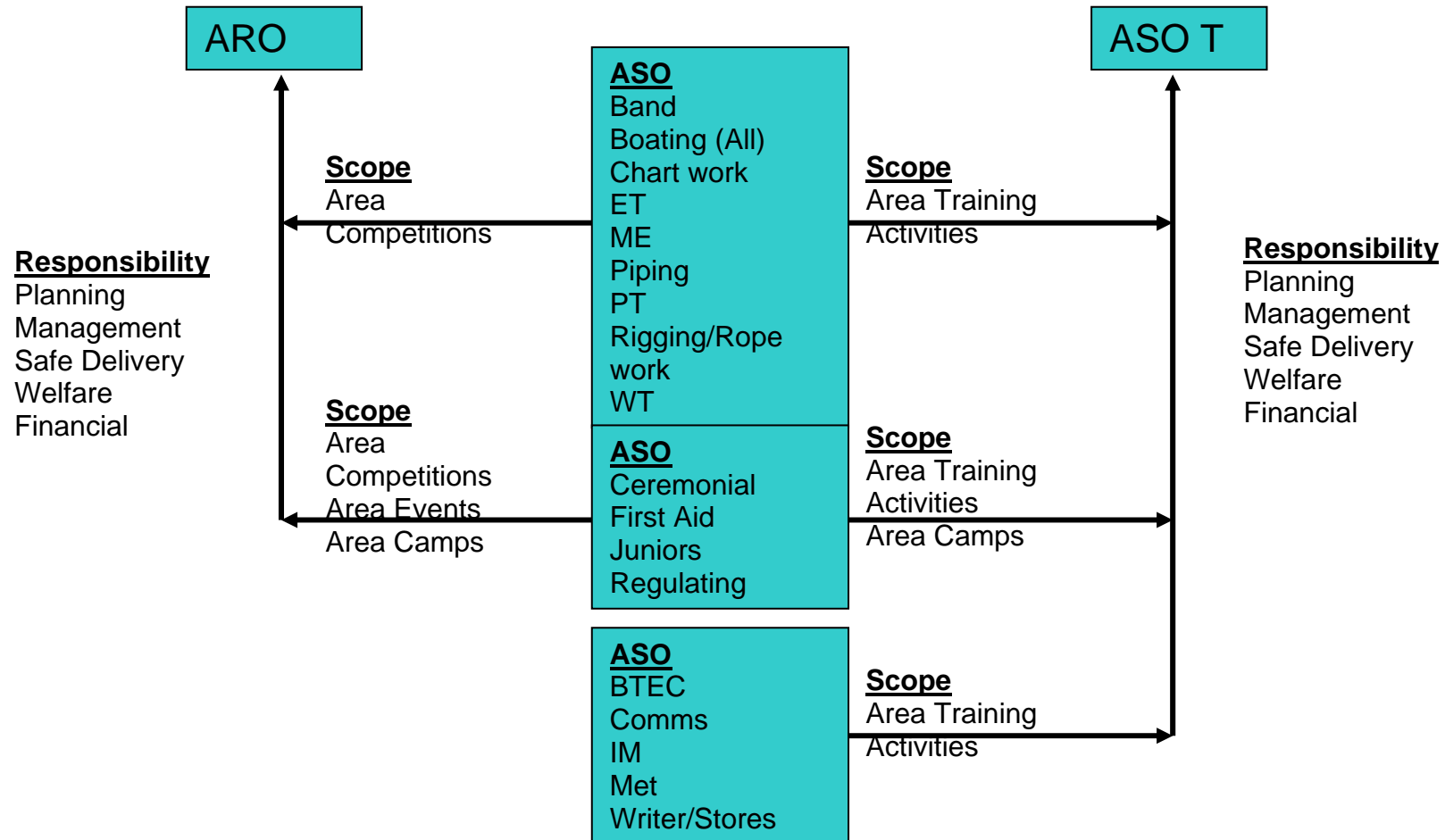

SCC NON OPERATIONAL UNIFORMED MANAGEMENT STRUCTURE

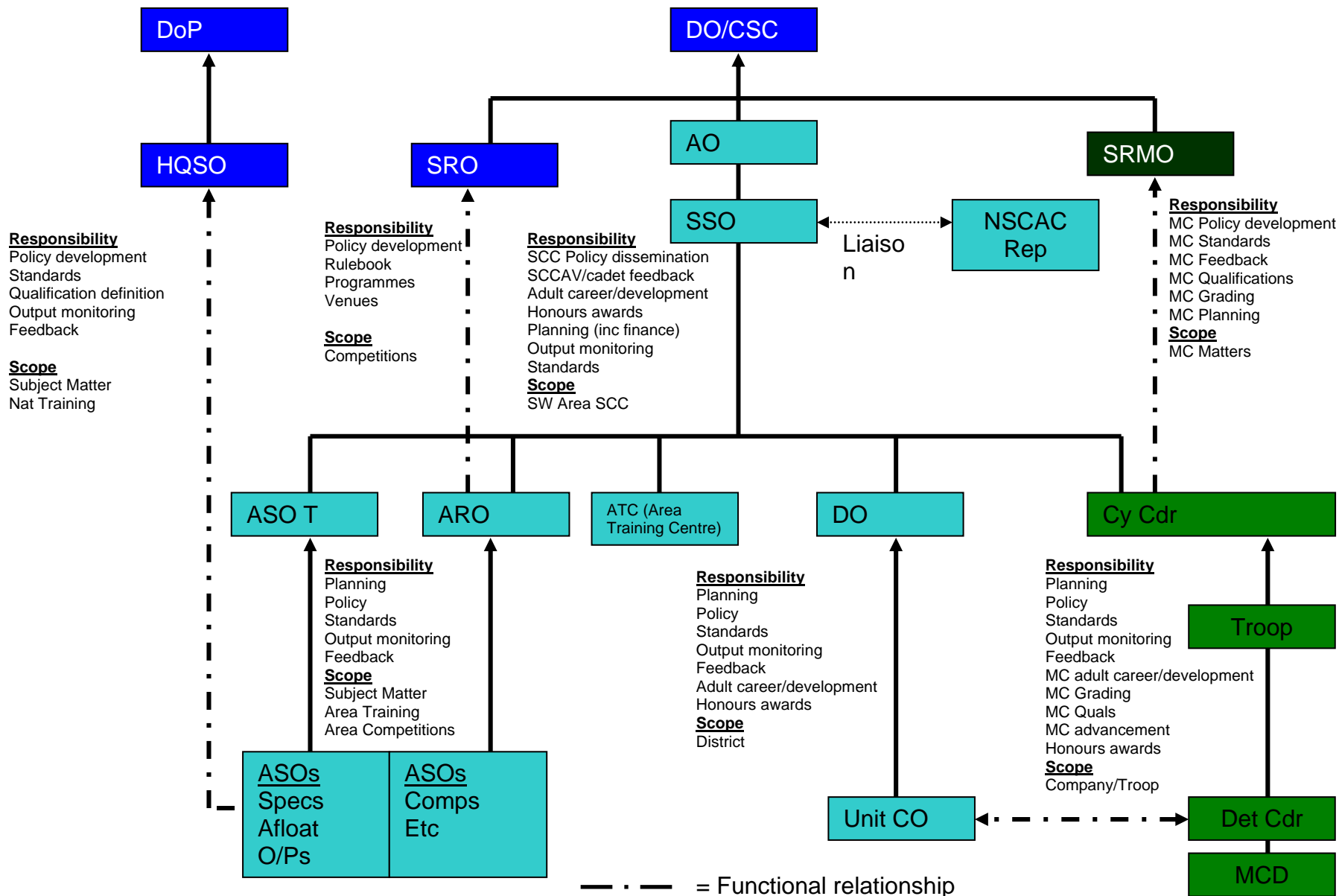

THE SEA CADET CORPS – MARINE CADET SECTION
2009 & 2010 FIELD ASSESSMENT DATES

2009

<u>COMPANY</u>	<u>DATE</u>	<u>TRAINING AREA</u>	<u>REMARKS</u>
Bravo	2 nd May 2009	Nesscliff	Completed
Bravo	16 th May 2009	Nesscliff	
Zulu	4 th July 2009		Jersey Field Assessment?
Zulu	5 th July 2009?		Jersey Field Assessment?
Lima	5 th Sept 2009		
Alpha	12 th Sept 2009	Swynnerton	
Zulu	19 th Sept 2009		Guernsey Field Assessment?
Zulu	26 th Sept 2009		Guernsey Field Assessment?
X-Ray	3 rd Oct 2009		Including Malta (TBC)
Alpha	17 th Oct 2009	Caerwent	
X-Ray	24/25 th Oct 2009		Malta Field Assessment (TBC)
Yankee	31 st October 2009	Garelochhead Camp	

2010

<u>COMPANY</u>	<u>DATE</u>	<u>TRAINING AREA</u>	<u>REMARKS</u>
Alpha	11 th Sept 2010	Swynnerton	
X-Ray	2 nd Oct 2010		
Alpha	9 th Oct 2010	Caerwent	
X-Ray	16/17 Oct 2010	Malta	Malta Field Assessment
Bravo			
Bravo			
Bravo			
Lima			
Yankee			
Zulu			
Zulu			

**Annex Di
Coy Cdr's & CSM's**

L98A2 Conversion Courses No 5 (L&SE)SATT

Ser	Course No (a)	Dates (b)	Venue (c)	Course Type (d)	Student Places (e)
1		25 Apr 09	ATR Pirbright	L98A2 Conversion SATT Staff Only	
2	501/09	26 Apr 09	ATR Pirbright	L98A2 Conversion See Note	40
3	501B/09	25 Apr 09	ATR Pirbright	4 Year Re-Qual	As Req.
4	502/09	16 - 17 May 09	ATR Pirbright	L98A2 Conversion See Note	40
5	502B/09	16 May 09	ATR Pirbright	4 Year Re-Qual	As Req.
6	503/09	6 -7 Jun 09	ATR Pirbright	L98A2 Conversion See Note	40

Note

The L98A2 conversion course lasts for 1 day and after training and successful completion of a WHT includes a live fire. ACFV who have a current L85A2 WHT should only require a half day conversion course.

The priority groups for conversion are existing L98A1 RCOs and WI, and the three programmed courses are **only** for CFAV who fall into one or both of these two groups.

If spaces are available on Course 503/09 consideration will be given to candidates who are booked on Course 504/09 SA(SR)07 and have existing L98A1 WHT.

All those attending the conversion courses will be given the opportunity to take (and pass) a L98A1 WHT. This should ensure that no matter where your Summer Camps are this year, and no matter whether they have A1s or A2s, your camp staff will be qualified on both.

OC No 5 (London & South East) SATT (5SATT)

Sqn Ldr Neal Gunter RAFVR(T)

OCs SATTs and HQAC Shooting Project Officers

1. No 1 (North) SATT

Sqn Ldr Bob Southwell RAFVR(T)

2. Northern Ireland SATT(NISATT) (Currently in suspension due to lack of staff. Task covered by ScotSATT)

3. South West SATT (SWSATT) and Deputy OC Central SATT

Sqn Ldr Paul Upham RAFVR(T)

4. The Scottish SATT (ScotSATT)

Sqn Ldr Garry Donald RAFVR(T)

Annex E to
Coy Cdr's & CSM's

